

4

3

2

1

Specifications:
Coverage: 500 sq. ft to 3,300 sq ft space
Adjusts up to 6 tons/2,400 CFM
Replacement Lamp: AS-IH-1013
Includes Wall Plug-in Transformer(94-135)

Patented Adjustable Dual Spectrum Air Treatment System-Photon Clarifier can be calibrated in sq ft of CFM

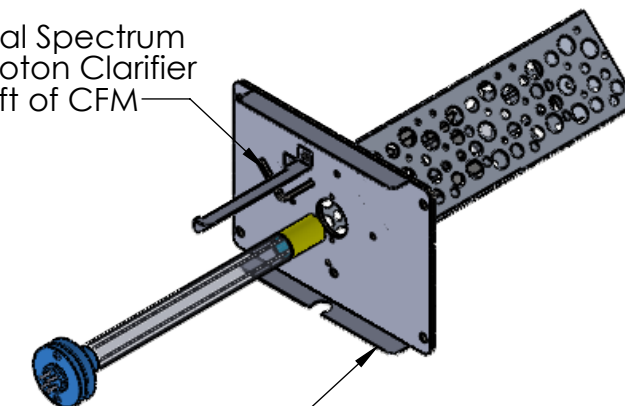
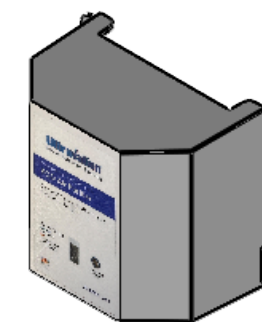
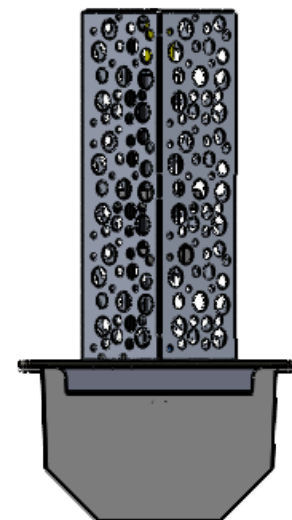

Mounting Plate: Modular Design for small footprint and easy Lamp replacement.

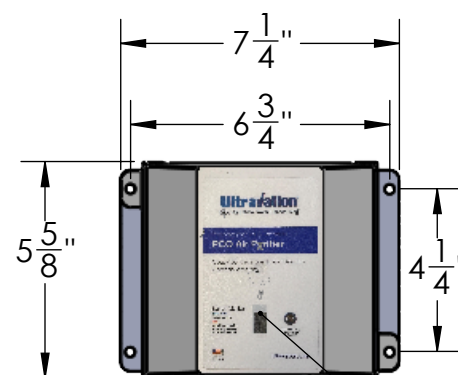

System Monitor Green/Blue LED: System Operation is Good  
Red LED: Lamp/Service Required

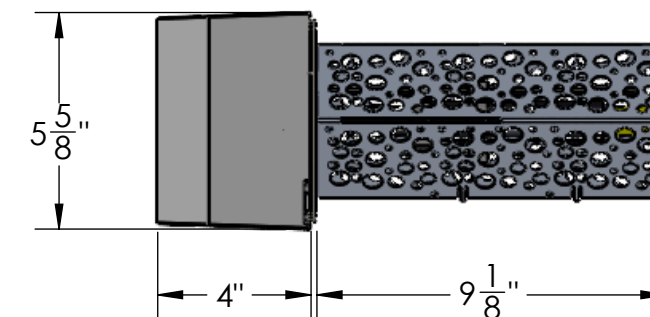

**Ultravation**  
Better Air | Better Water | Better Living™

This product is 24VAC – **DO NOT** connect the supplied wires directly to line voltage.

Please read the following instructions regarding wall plugin usage (depending on product purchased):



Part Number: 94-135

Using the provided power wires, attach each lead to each terminal on the plugin transformer. Wires may be fitted to either terminal as they are non-polarized.

OR



Part Number: 94-135-DC

Use the provided wall plugin transformer to power your unit only.

DC-15-24VTF

REV 1 06/13/21

**PROPRIETARY AND CONFIDENTIAL**  
THE INFORMATION CONTAINED IN THIS DRAWING IS THE SOLE PROPERTY OF <INSERT COMPANY NAME HERE>. ANY REPRODUCTION IN PART OR AS A WHOLE WITHOUT THE WRITTEN PERMISSION OF <INSERT COMPANY NAME HERE> IS PROHIBITED.

<b>Ultravation</b> Better Air Better Water   Better Living™		UNLESS OTHERWISE SPECIFIED:		NAME	DATE	TITLE: <b>UVPhotomax 120 VAC</b>
ULTRAVATION, INC. 67 TUBBS AVENUE BRANDON VT. 05773 PHONE (866) 468-8247		DIMENSIONS ARE IN INCHES TOLERANCES: FRACTIONAL ± ANGULAR: MACH ± BEND ± TWO PLACE DECIMAL ± THREE PLACE DECIMAL ±		DRAWN	H Kelley 9/10/2025	
APPLICATION		INTERPRET GEOMETRIC TOLERANCING PER:		CHECKED		
DO NOT SCALE DRAWING		MATERIAL		ENG APPR.		
		FINISH		MFG APPR.		
				Q.A.		SIZE DWG. NO. REV
				COMMENTS:		<b>B</b> PTE-1200
						SCALE: 1:12 WEIGHT: SHEET 1 OF 1

4

3

2

1

B

B

A

A