

ProgressiveMedia™ Whole House Air Cleaning

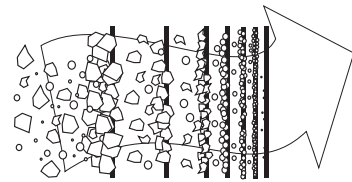

High performance progressive density filtration for better air cleaning and long filter life



Homeowner / User Guide

Models 90-005 90-007 90-016 90-106 90-115
90-006 90-015 90-105 90-107 90-116

1-866-GO-UV-AIR (468-8247)
ultravation.com

DC-OM-ST Rev 3

Ultravation®

Better Air | Better Water | Better Living™

OPEN >>>>

Thank you for purchasing an Ultravation®
Professional Indoor Air Quality Product

ProgressiveMedia™ Whole House Air Cleaner

We recommend that this unit be installed and maintained by a trained HVAC professional technician.

Shipping and Packaging List:

- Filter housing including access door
- MERV 11 or MERV 13 ProgressiveMedia™ Air Filter
- Warranty Registration

Introduction and Application

Your Ultravation® ProgressiveMedia Air Cleaner is a high efficiency air filtration system designed to remove dirt, dust, pollen, and other microscopic particles from the air that circulates through it. By adding it to your HVAC system, you are creating a cleaner indoor living environment for your whole household.

The filter works by trapping particles in its pleats and fibers. The filter is layered with progressively tighter density from the air entry to exit. It captures the largest particles early and increasingly smaller particles through its thickness. By holding dirt in its entire thickness and because of its extra large surface area, Ultravation® ProgressiveMedia™ has extremely high dirt holding capacity, so you will enjoy very long useful filter life. Its size and layered construction also creates minimal air flow restriction, enhancing HVAC system efficiency.

This media air cleaner is designed to be installed in a forced air heating, cooling and ventilation system. It should be installed so that all the system air is circulated through the filter. The air cleaner will only filter the air that is circulated through it. For maximum filtration effect, set your blower to operate continuously.

Application with a Humidifier

ProgressiveMedia™ Air Cleaners are completely compatible with humidifiers. However, avoid applications where water mist will reach the media. When an evaporative type humidifier is used, it may be installed between the furnace warm air duct and the return air duct without affecting the air cleaner. Atomizing and spray type humidifiers should be installed at least six feet between the air cleaner and humidifier.

Air Conditioning

The air cleaner should be installed upstream of the cooling coil to keep the coil clean. This will improve cooling efficiency and reduce air conditioning coil maintenance. Better efficiency directly affects energy costs, so it pays to replace the filter at regular intervals (see Maintenance). Conversely, failure to replace the filter wastes energy and it may cause damage to the HVAC system.

Maintenance

The filter media in your air cleaner must be changed periodically. The frequency of filter replacement is best determined by visual examination. However, a biannual replacement of the filter is strongly recommended, more often in areas where dust is known to be excessive. **Replacement filters** can be obtained through your installing contractor or local dealer.

Steps for replacing filter:

1. Open the access door by pressing down on handle then pull top of door forward slightly and lift.
2. Pull out used filter and discard.
3. Slide new filter into cabinet with airflow label pointing in the direction of the airflow.
4. Replace access door.

Warranty

Ultravation warrants this product against any defects in material or workmanship for a period of ten years after date of installation (minimum expected lifetime of product within normal operating conditions), with the exception of the disposable media filter, the ductwork and installation.

This warranty does not include damage to the unit from accident, misuse or improper installation. If this product should become defective during the warranty period, Ultravation will repair or elect to replace the product free of charge. Ultravation will return repaired or replaced warranted products pre-paid, provided that the product was delivered pre-paid.

Ultravation shall have no responsibilities for charges incurred by the customer for installation or removal of warranted items. Liability is limited only to the replacement or repair of this product.

This warranty gives you specific legal rights, and you may also have other rights, which vary from state to state. All returns must be accompanied by a return authorization number, which may be obtained by contacting Ultravation, Inc.

Ultravation, Inc.

67 Tubbs Ave, Brandon, VT 05733

Phone: 802-287-9735 • Fax: 802-287-9203

www.ultravation.com • info@ultravation.com

Ultravation®

Better Air | Better Water | Better Living™

ultravation.com

Replacement Filters

Model	Dimensions	MERV 11 Filter Part Number	MERV 13 Filter Part Number
90-005 / 90-105	16x25x3	91-007	-
90-006 / 90-106	16x25x5	91-005	91-025
90-007 / 90-107	20x25x5	91-006	91-026
90-015 / 90-115	16x20x5	91-012	91-027
90-016 / 90-116	20x20x5	91-013	91-028

For more information on MERV ratings, visit ultravation.com/progressive-air-filtration/. See serial number label inside of equipment door for unit replacement part numbers.

Ultravation®

Better Air | Better Water | Better Living™

ultravation.com

Typical installation of an Ultravation® ProgressiveMedia™ Air Cleaner

Installation Requirements

The desired location for installation of an Ultravation® ProgressiveMedia™ Air Cleaner is in the return air duct next to the blower compartment. In this location, the blower motor and internal components will be kept clean. By installing the air cleaner in the return (upstream from the cooling coils) the HVAC cooling coils in particular, will be kept clean. This protection increases coil life, improving overall system efficiency, saves power, and reduces maintenance costs.

Do not install this unit in the supply duct. Be sure to plan adequate space to allow filter replacement. Before installation is complete, seal all joints and seams airtight with duct tape or caulking.

Once a ProgressiveMedia™ Air Cleaner is installed, it is very important to maintain the unit by changing the filter periodically so as not to obstruct airflow, which can damage components and increase energy costs.

Transitions

If the air duct does not fit the air cleaner cabinet opening, gradual transitions are recommended to reduce air turbulence through the air cleaner and maximize efficiency. Not more than 20 degrees (about 4" per running foot) of expansion should be used on each side of the transition fitting. (See diagram below)

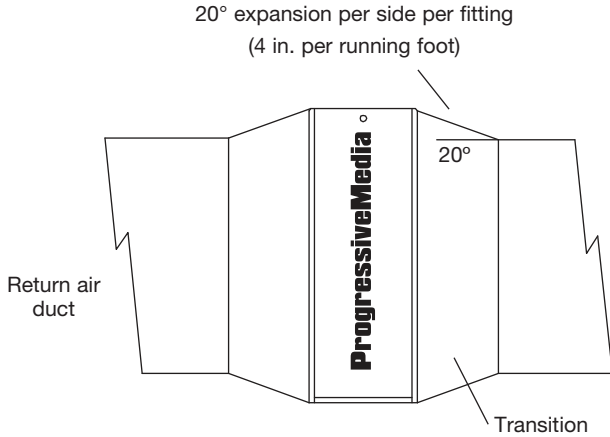

Turning Vanes

If the air cleaner is installed adjacent to a 90-degree duct elbow, add turning vanes inside the duct to improve the air distribution across the face of the air cleaner. (See diagram below)

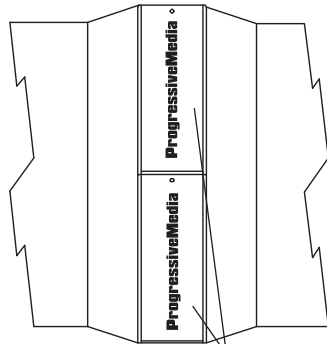
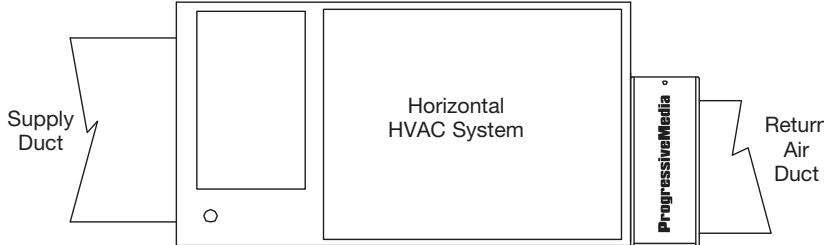
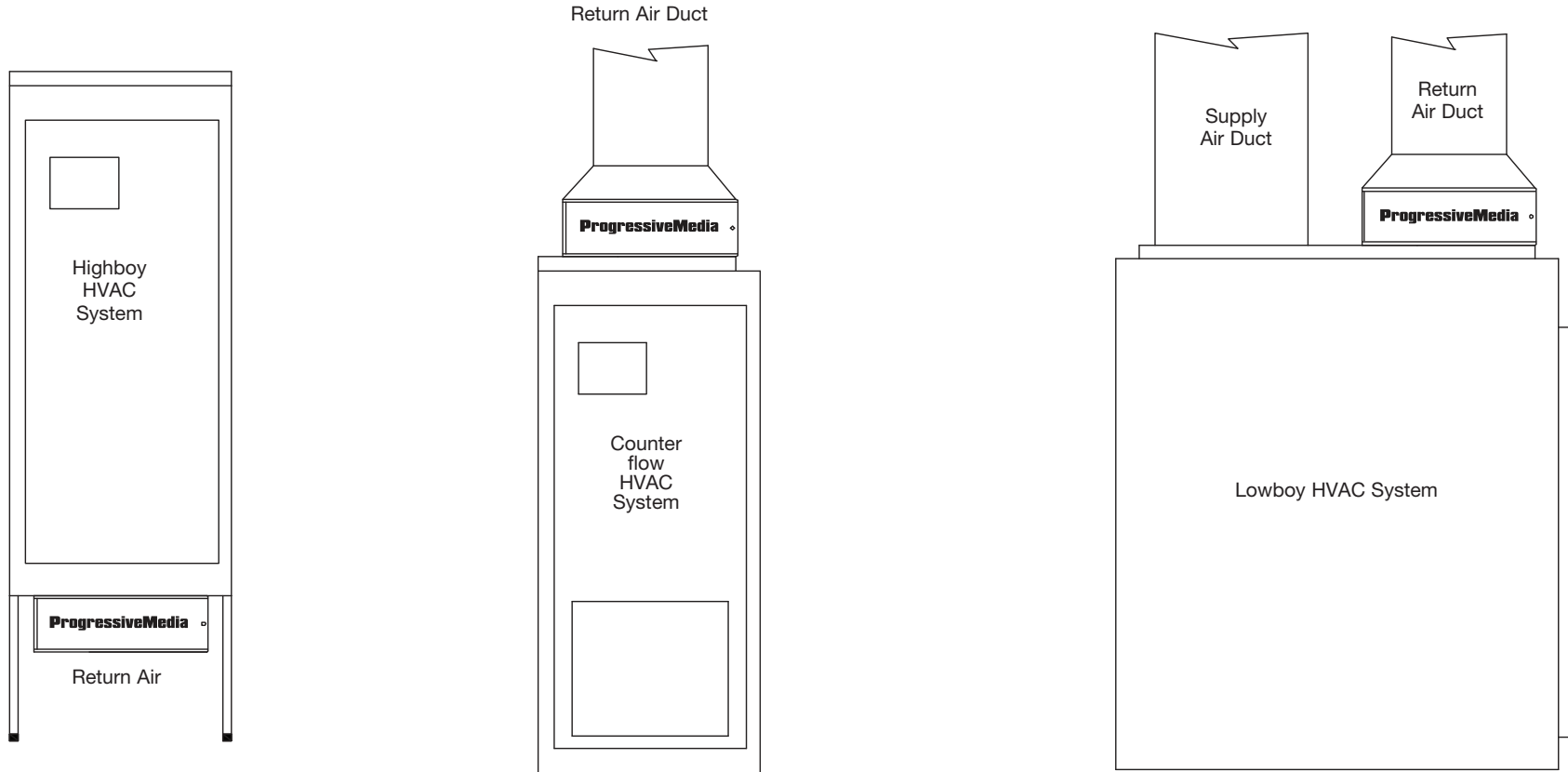
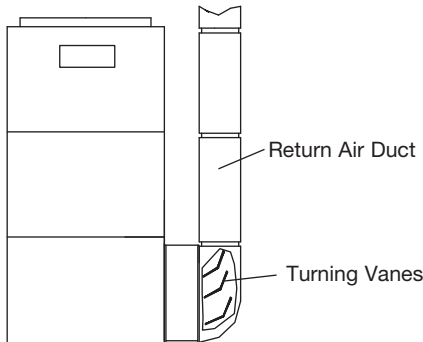

Two or more ProgressiveMedia™ Air Cleaners used in a high capacity HVAC system

ProgressiveMedia™ Air Cleaners have been designed for use with virtually all types of HVAC systems.