

Specifications
Material: 22 Gauge Domestic Steel (Low Lead Content)
Designed Weight Capacity: 250 lbs
Air Flow Range: 600 to 1,350 CFM
Merv 11 - 16x20x5 Replacement Filter: 91-012
Merv 13 - 16x20x5 Replacement Filter: 91-027

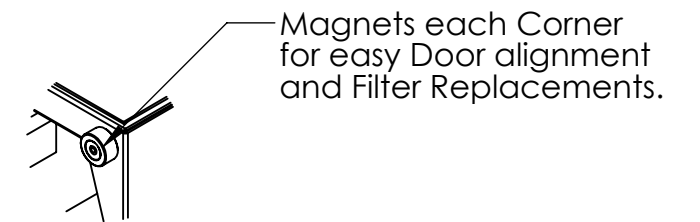

DETAIL A
SCALE 1 : 2

Pressure Differential Across the Ultravation Filter Across Various Flow Rates

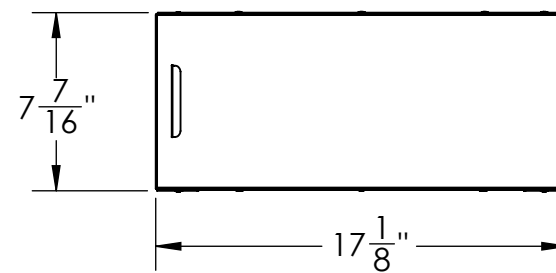
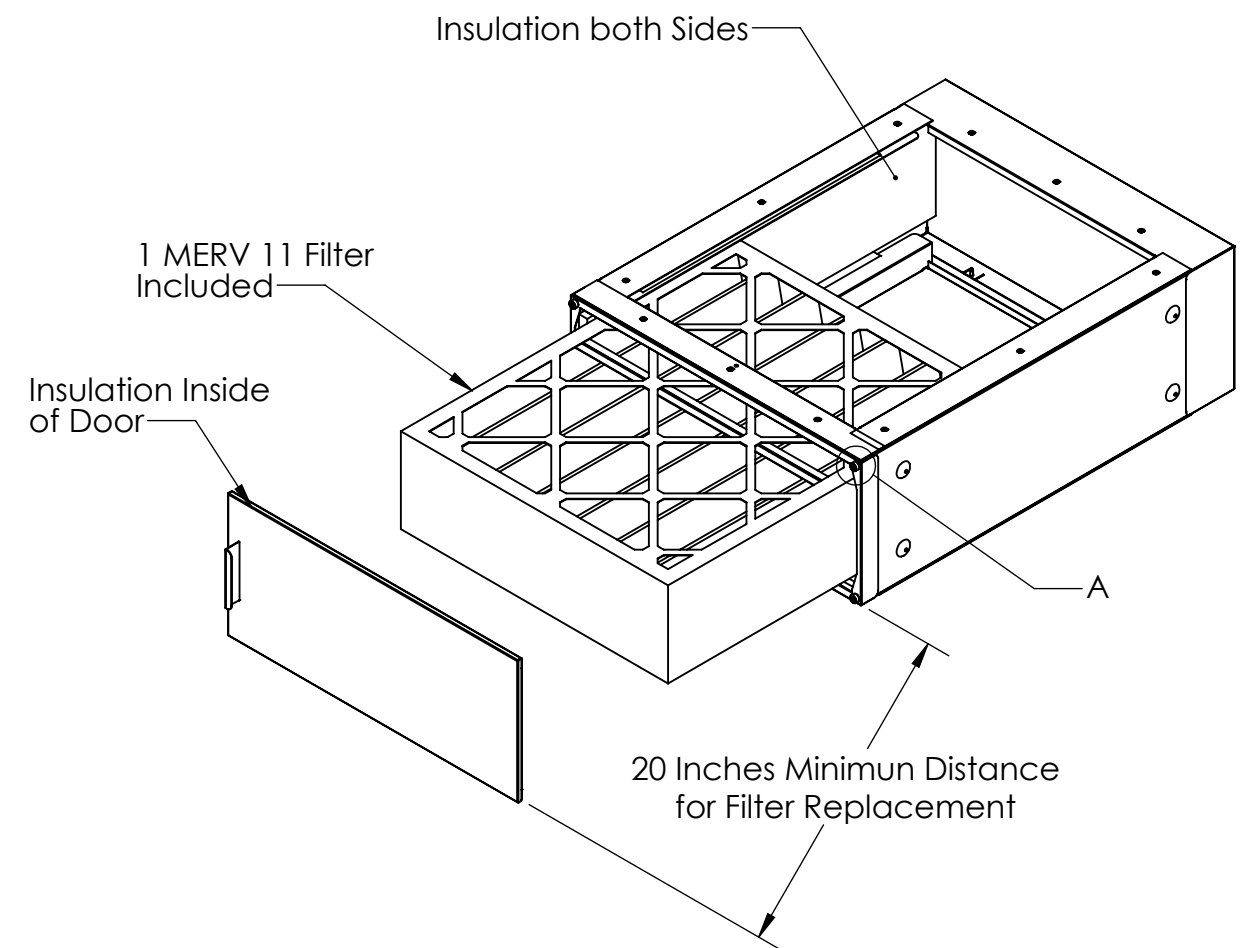
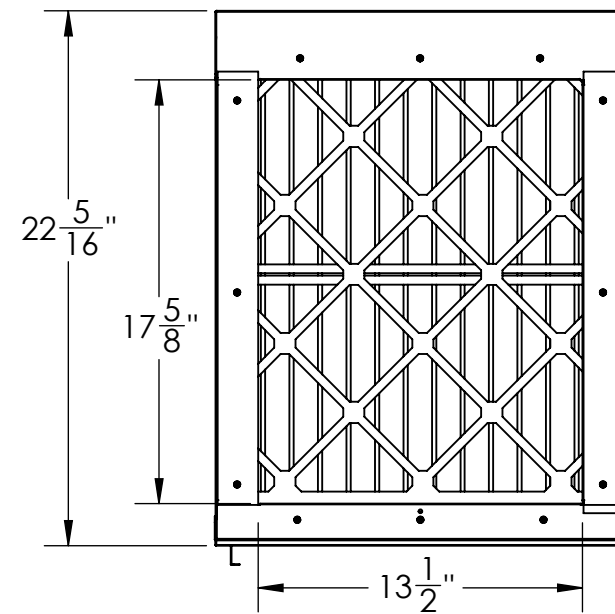
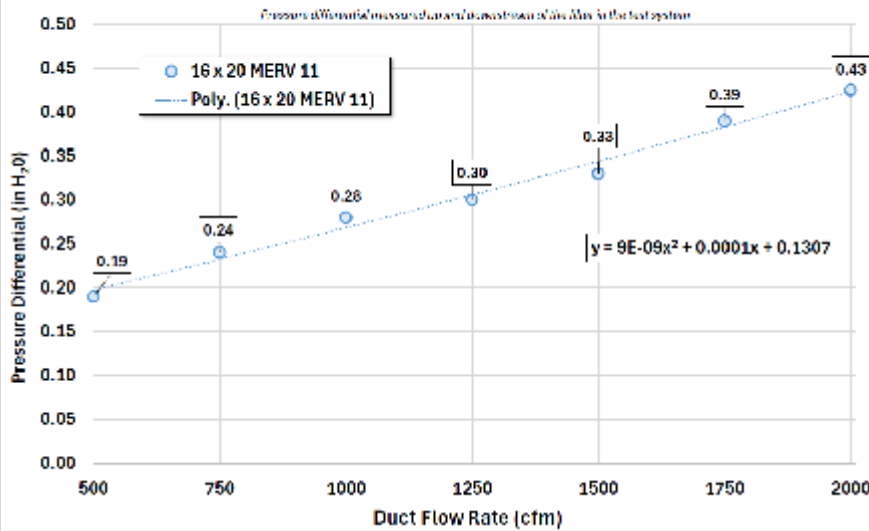

PROPRIETARY AND CONFIDENTIAL
THE INFORMATION CONTAINED IN THIS DRAWING IS THE SOLE PROPERTY OF ULTRAVATION. ANY REPRODUCTION IN PART OR AS A WHOLE WITHOUT THE WRITTEN PERMISSION OF ULTRAVATION IS PROHIBITED.

		UNLESS OTHERWISE SPECIFIED:		NAME	DATE
		DIMENSIONS ARE IN INCHES TOLERANCES: FRACTIONAL ± ANGULAR: MACH ± BEND ± TWO PLACE DECIMAL ± THREE PLACE DECIMAL ±		DRAWN	H Kelley 6/9/2025
ULTRAVATION, INC. 67 TUBBS AVENUE BRANDON VT. 05773 PHONE (866) 468-8247		INTERPRET GEOMETRIC TOLERANCING PER: MATERIAL See Specifications FINISH See Comments		CHECKED ENG APPR. MFG APPR.	TITLE: <h1>Air Handler Base Unit</h1>
		APPLICATION DO NOT SCALE DRAWING		Q.A. COMMENTS: Standard Finish: Powder Coat White	
				SCALE: 1:8 WEIGHT:	REV B SHEET 1 OF 1