

Specifications
Material: 22 Gauge Domestic Steel (Low Lead Content)
Designed Weight Capacity: 250 lbs
Air Flow Range: 600 to 2,000 CFM
Merv 11 - 20x20x5 Replacement Filter: 91-013
Merv 13 - 20x20x5 Replacement Filter: 91-028

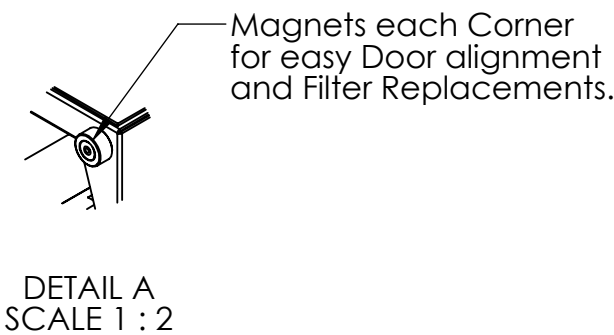

Pressure Differential Across the Ultravation Filter Across Various Flow Rates

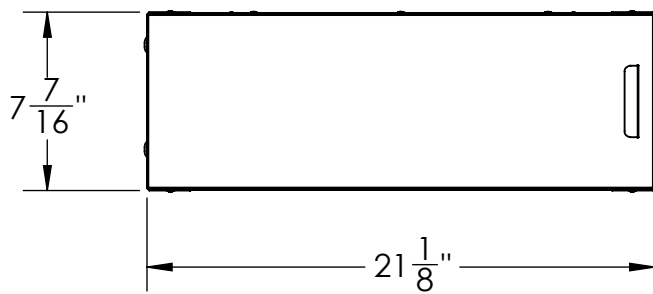
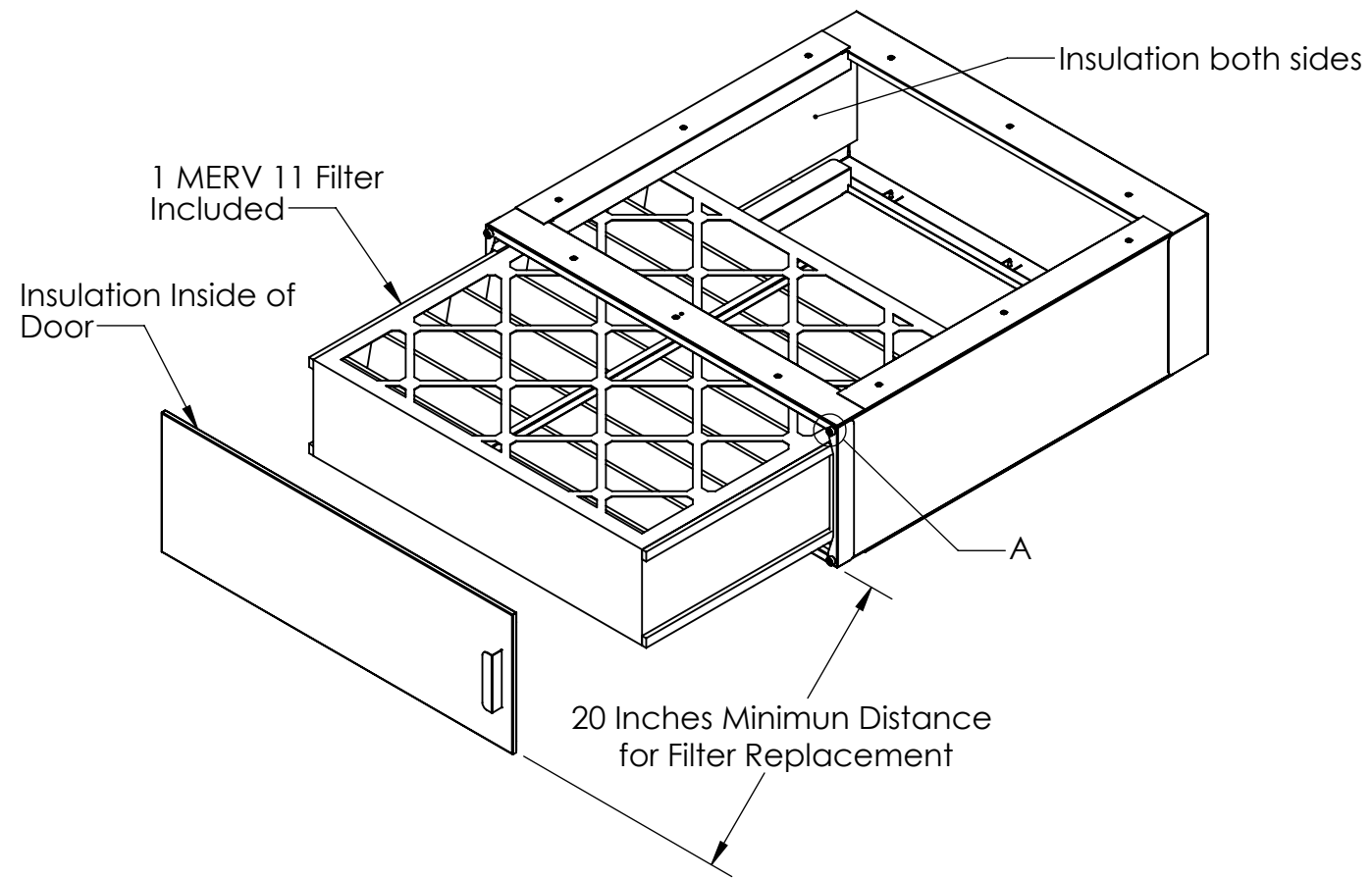
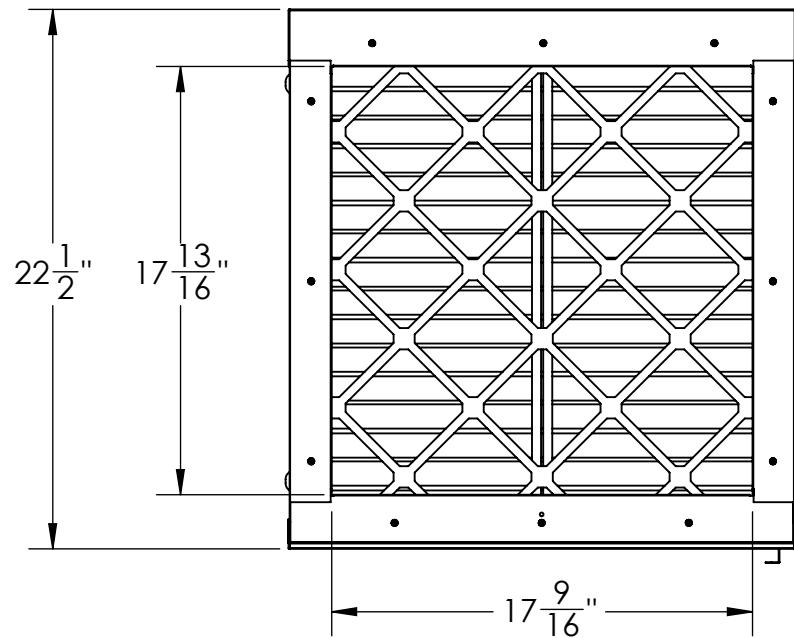
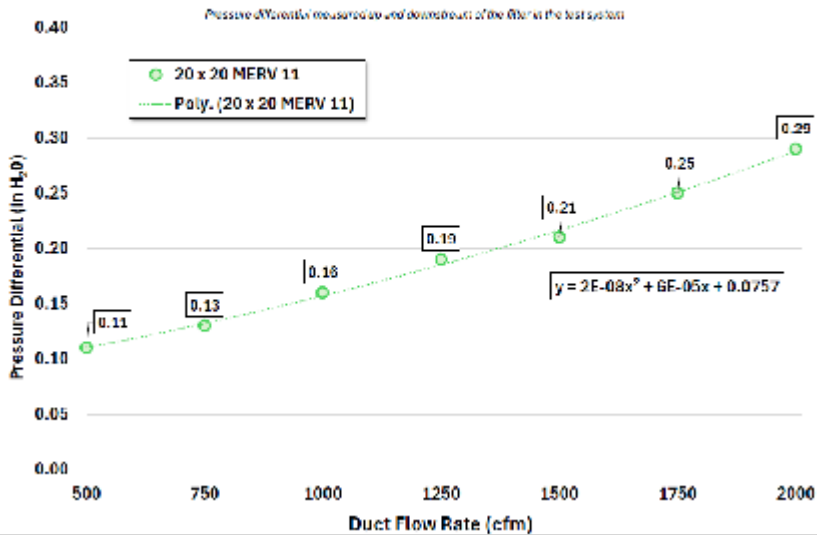

PROPRIETARY AND CONFIDENTIAL
 THE INFORMATION CONTAINED IN THIS DRAWING IS THE SOLE PROPERTY OF ULTRAVATION. ANY REPRODUCTION IN PART OR AS A WHOLE WITHOUT THE WRITTEN PERMISSION OF ULTRAVATION IS PROHIBITED.

 ULTRAVATION, INC. 67 TUBBS AVENUE BRANDON VT. 05773 PHONE (866) 468-8247	UNLESS OTHERWISE SPECIFIED: DIMENSIONS ARE IN INCHES TOLERANCES: FRACTIONAL ± ANGULAR: MACH ± BEND ± TWO PLACE DECIMAL ± THREE PLACE DECIMAL ±	NAME: H Kelley DATE: 6/9/2025	TITLE: <h1 style="text-align: center;">Air Handler Base Unit</h1>
	INTERPRET GEOMETRIC TOLERANCING PER: MATERIAL: See Specifications FINISH: See Comments	DRAWN: H Kelley CHECKED: ENG APPR.: MFG APPR.: Q.A.: COMMENTS: Standard Finish: Powder Coat White	