

Specifications
Material: 22 Gauge Domestic Steel (Low Lead Content)
Designed Weight Capacity: 250 lbs
Air Flow Range: 600 to 1,350 CFM
Merv 11 - 16x20x5 Replacement Filter: 91-012
Merv 13 - 16x20x5 Replacement Filter: 91-027

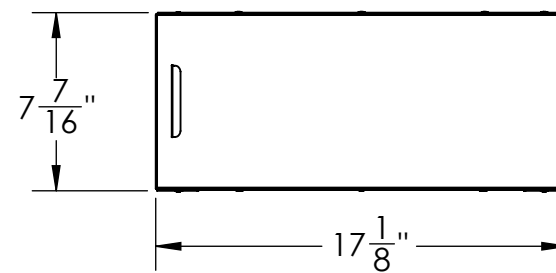
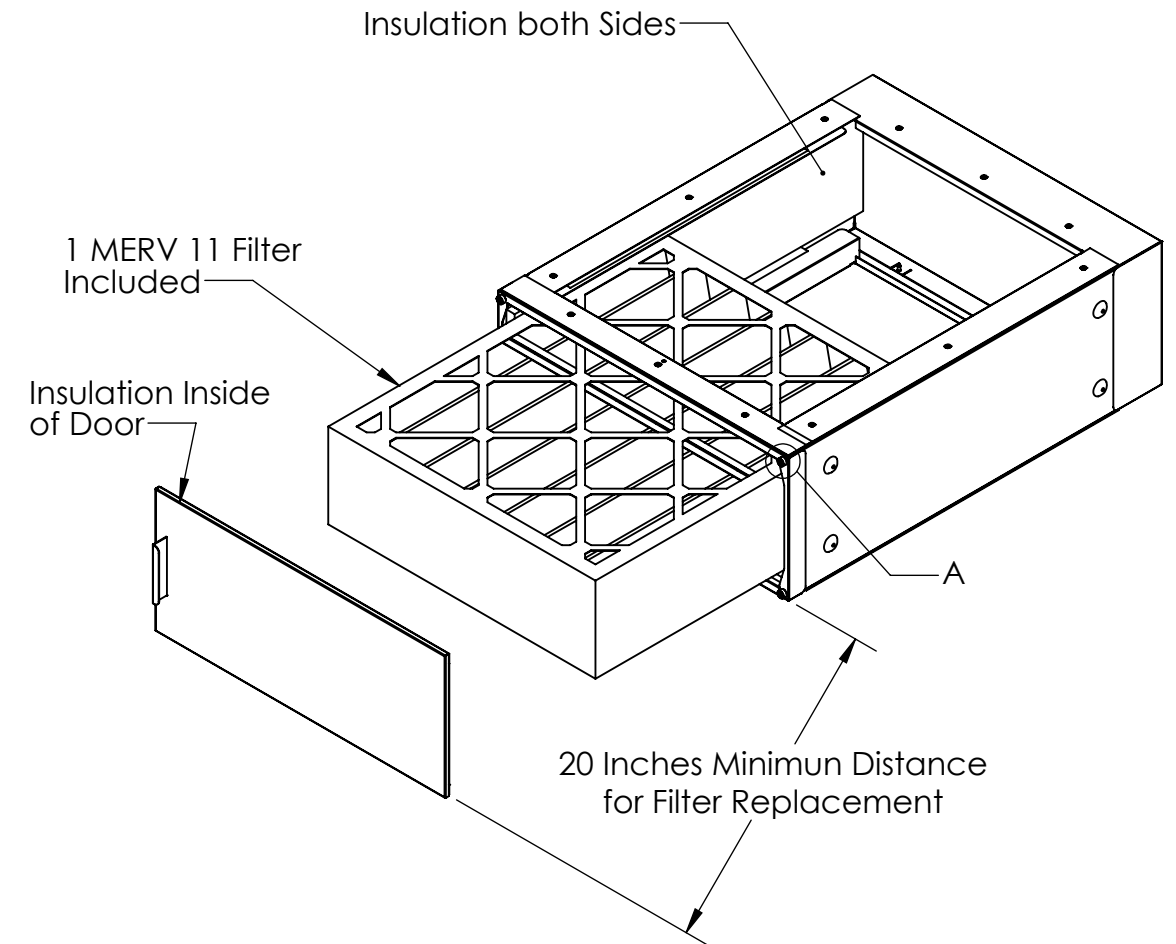
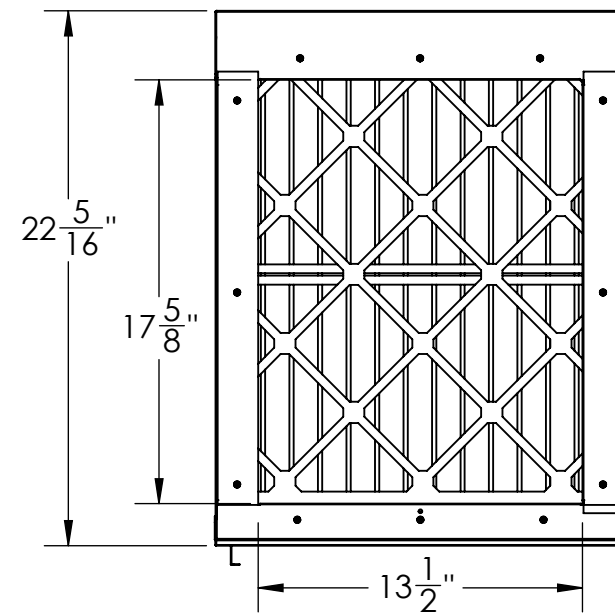

Magnets each Corner for easy Door alignment and Filter Replacements.

DETAIL A  
SCALE 1 : 2

Pressure Differential Across the Ultravation Filter Across Various Flow Rates

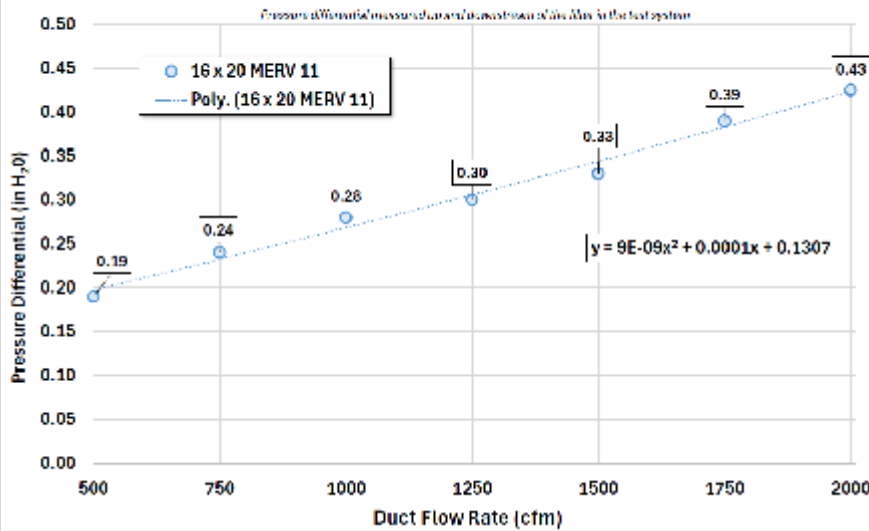

**PROPRIETARY AND CONFIDENTIAL**  
THE INFORMATION CONTAINED IN THIS DRAWING IS THE SOLE PROPERTY OF ULTRAVATION. ANY REPRODUCTION IN PART OR AS A WHOLE WITHOUT THE WRITTEN PERMISSION OF ULTRAVATION IS PROHIBITED.

 Better Air   Better Water   Better Living <b>ULTRAVATION, INC.</b> 67 TUBBS AVENUE BRANDON VT. 05773 PHONE (866) 468-8247	UNLESS OTHERWISE SPECIFIED:	NAME	DATE	<b>TITLE:</b> Air Handler Base Unit
	DIMENSIONS ARE IN INCHES TOLERANCES: FRACTIONAL ± ANGULAR: MACH ± BEND ± TWO PLACE DECIMAL ± THREE PLACE DECIMAL ± INTERPRET GEOMETRIC TOLERANCING PER: MATERIAL See Specifications FINISH See Comments	DRAWN CHECKED ENG APPR. MFG APPR. Q.A. COMMENTS: Painted Door with Galvanized Cabinet	H Kelley	
APPLICATION	DO NOT SCALE DRAWING	SCALE: 1:8	WEIGHT:	SIZE <b>B</b> DWG. NO. 90-151 AHBU 16x20x5 REV <b>B</b> SHEET 1 OF 1