

Specifications
Material: 22 Gauge Domestic Steel (Low Lead Content)
Design Weight Capacity: 275 lbs.
Pressure Drop @ 1,000 CFM 0.04 Inches of H ₂ O

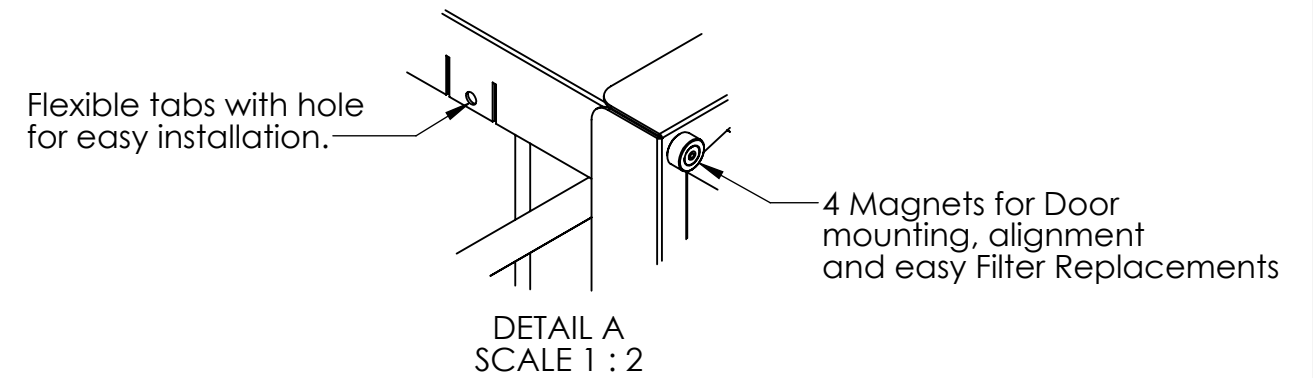

Pressure Differential Across the Ultravation Filter Across Various Flow Rates

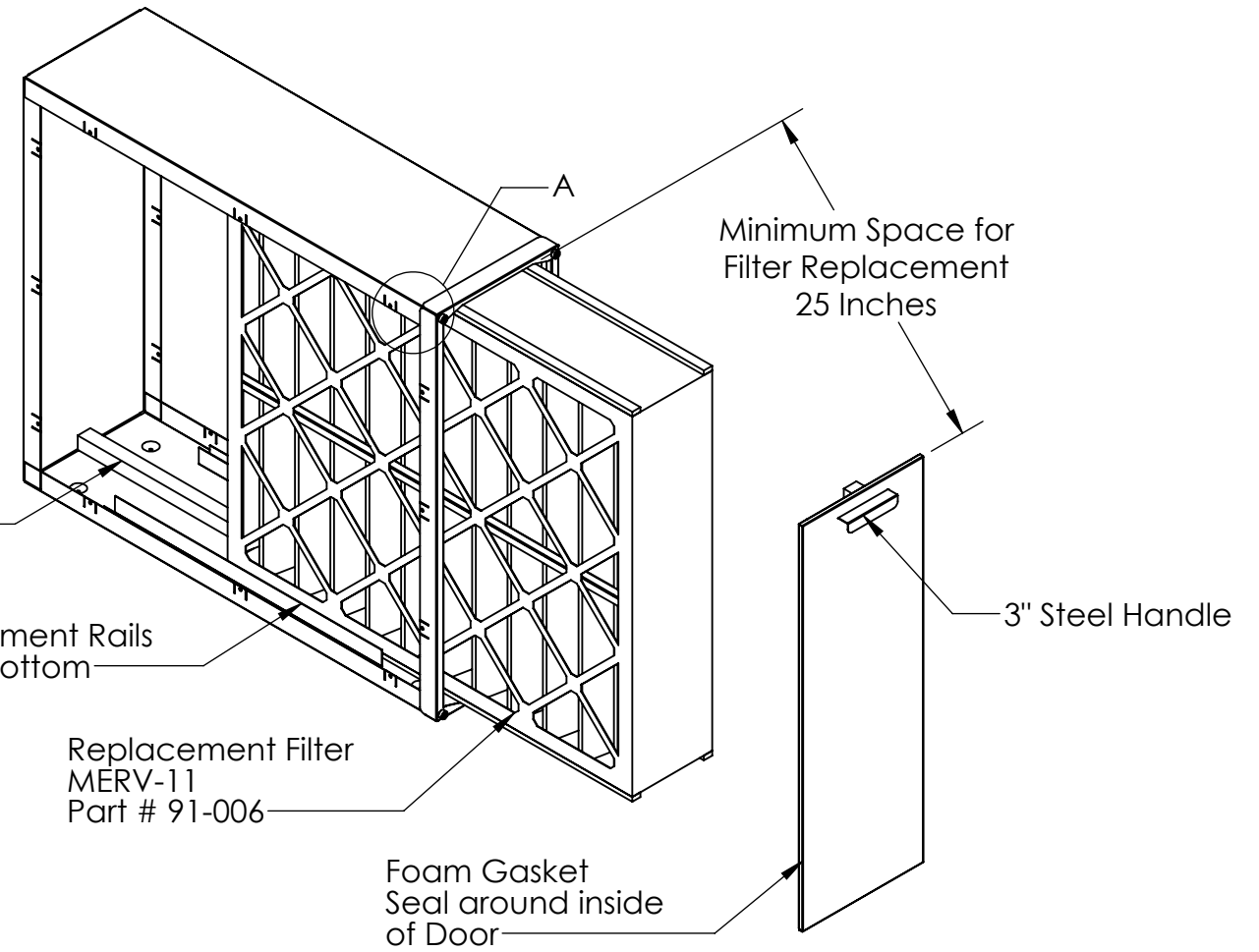
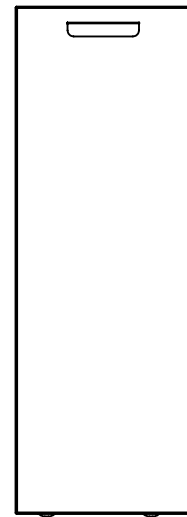
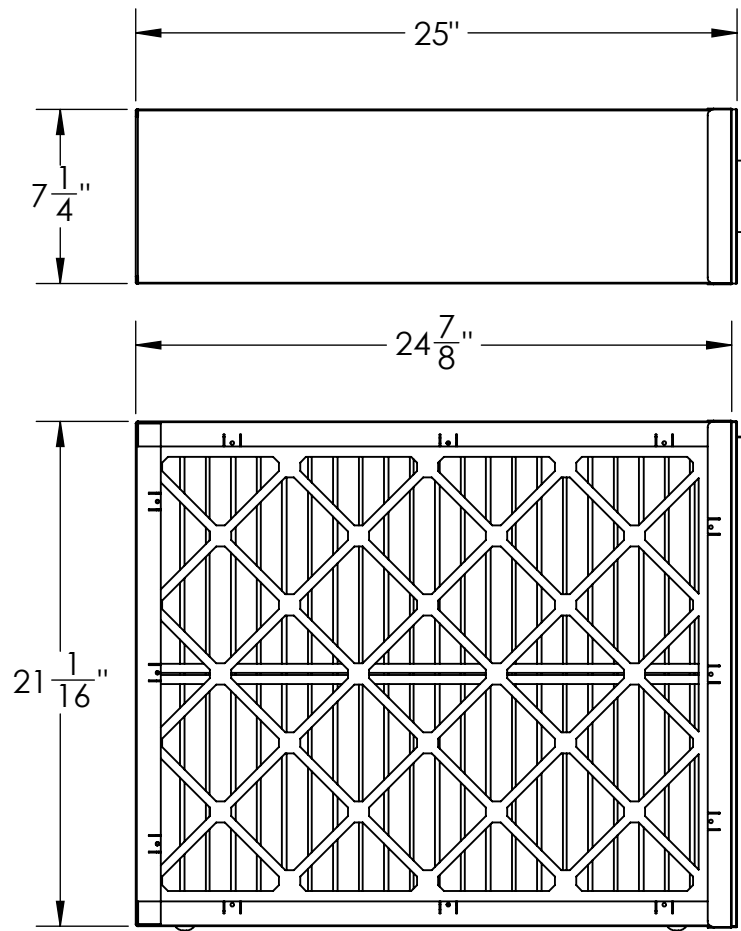
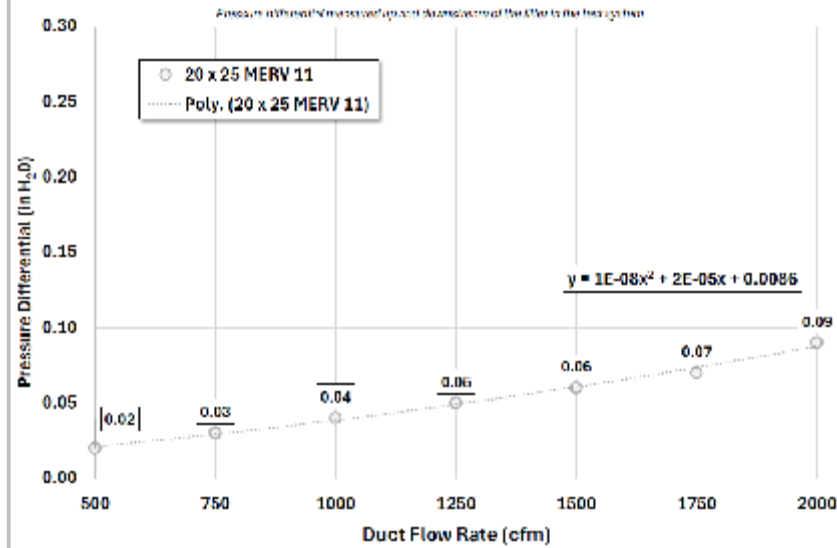

<p>Better Air Better Water Better Living</p> <p>ULTRAVATION, INC. 67 TUBBS AVENUE BRANDON VT. 05773 PHONE (866) 468-8247</p>	<p>PROPRIETARY AND CONFIDENTIAL</p> <p>THE INFORMATION CONTAINED IN THIS DRAWING IS THE SOLE PROPERTY OF ULTRAVATION. ANY REPRODUCTION IN PART OR AS A WHOLE WITHOUT THE WRITTEN PERMISSION OF ULTRAVATION IS PROHIBITED.</p> <p>MATERIAL: See Specifications FINISH: See Comments</p>	<p>NAME: H Kelley DATE: 6/6/2025</p>	<p>TITLE: ST 20x25x5 Media Air-Cleaner</p>
		<p>APPLICATION: DO NOT SCALE DRAWING</p>	