

4

3

2

1

Specifications
Material: 22 Gauge Domestic Steel (Low Lead Content)
Designed Weight Capacity: 250 lbs
Air Flow Range: 600 to 2,000 CFM
Merv 11 - 20x20x5 Replacement Filter: 91-013
Merv 13 - 20x20x5 Replacement Filter: 91-028

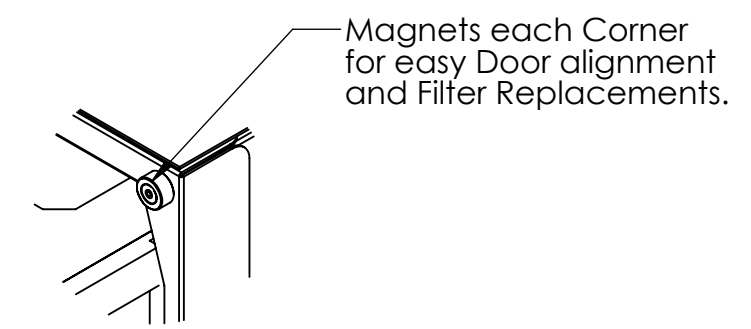
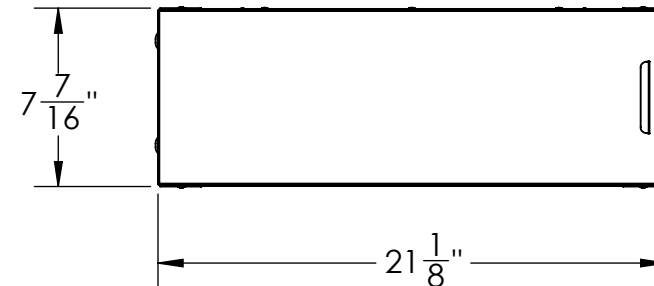
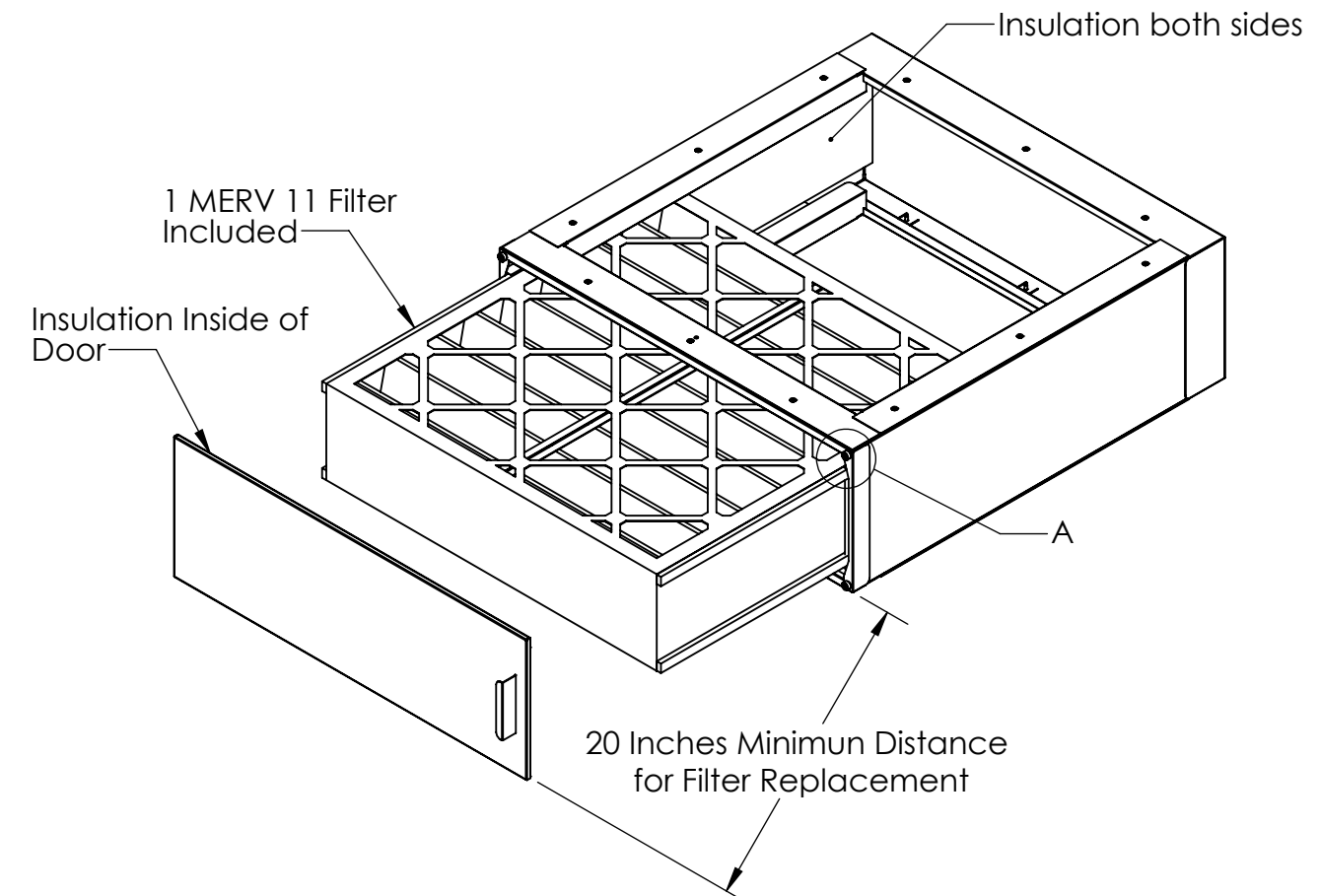
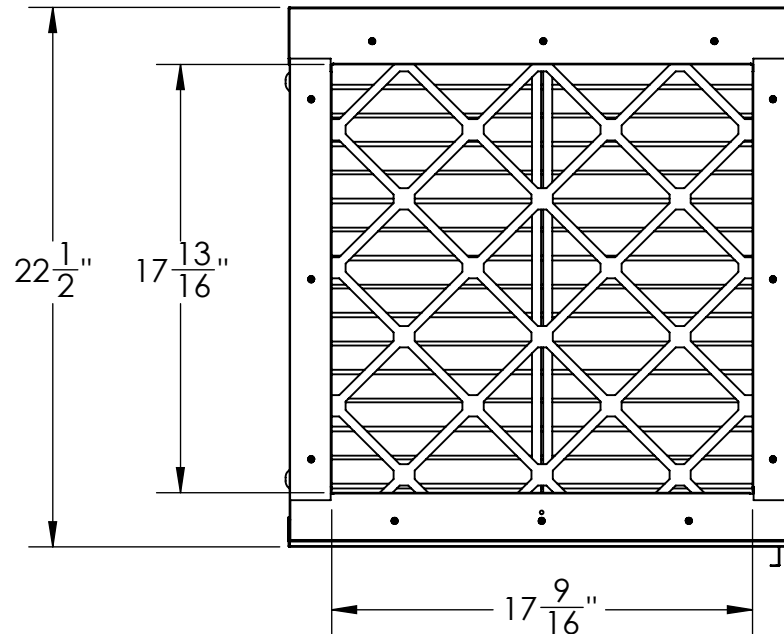

DETAIL A  
SCALE 1 : 2

Pressure Differential Across the Ultravation Filter  
Across Various Flow Rates

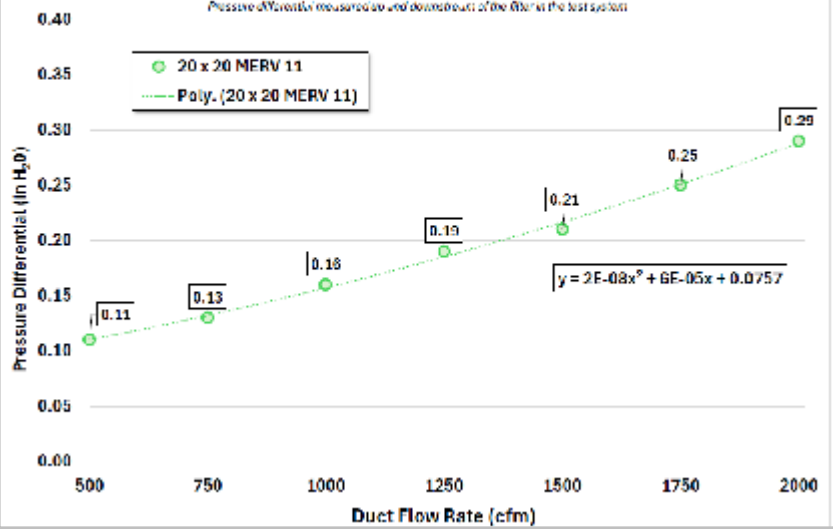

**PROPRIETARY AND CONFIDENTIAL**  
THE INFORMATION CONTAINED IN THIS DRAWING IS THE SOLE PROPERTY OF ULTRAVATION. ANY REPRODUCTION IN PART OR AS A WHOLE WITHOUT THE WRITTEN PERMISSION OF ULTRAVATION IS PROHIBITED.

	UNLESS OTHERWISE SPECIFIED:		NAME	DATE	<b>TITLE:</b>  <h2 style="text-align: center;">Air Handler Base Unit</h2>	
	DIMENSIONS ARE IN INCHES TOLERANCES: FRACTIONAL ± ANGULAR: MACH ± BEND ± TWO PLACE DECIMAL ± THREE PLACE DECIMAL ±	DRAWN CHECKED ENG APPR. MFG APPR.	H Kelley	6/9/2025		
ULTRAVATION, INC. 67 TUBBS AVENUE BRANDON VT. 05773 PHONE (866) 468-8247	INTERPRET GEOMETRIC TOLERANCING PER: MATERIAL See Specifications FINISH See Comments	COMMENTS: <b>Galvanized Cabinet with Galvanized Door</b>	Q.A.	SIZE <b>B</b>	DWG. NO. 90-452 AHBU 20x20x5	REV <b>B</b>
APPLICATION	DO NOT SCALE DRAWING	SCALE: 1:8	WEIGHT:	SHEET 1 OF 1		

4

3

2

1

B

B

A

A