

Specifications	
Material:	20/26 Gauge Domestic Steel (Low Lead Content)
Design Weight Capacity:	300 lbs.
Pressure Drop @ 1000 CFM:	.12 Inches of H ₂ O

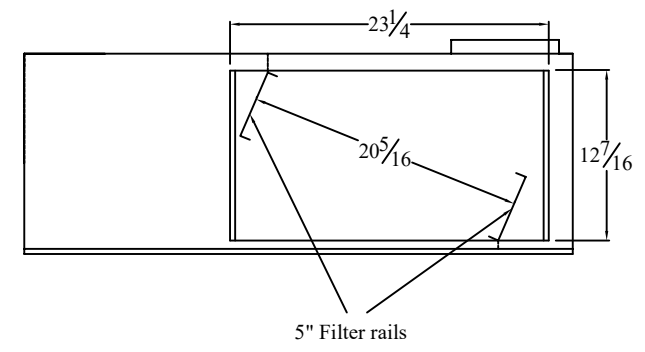
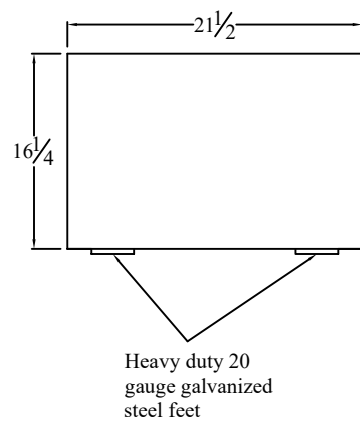
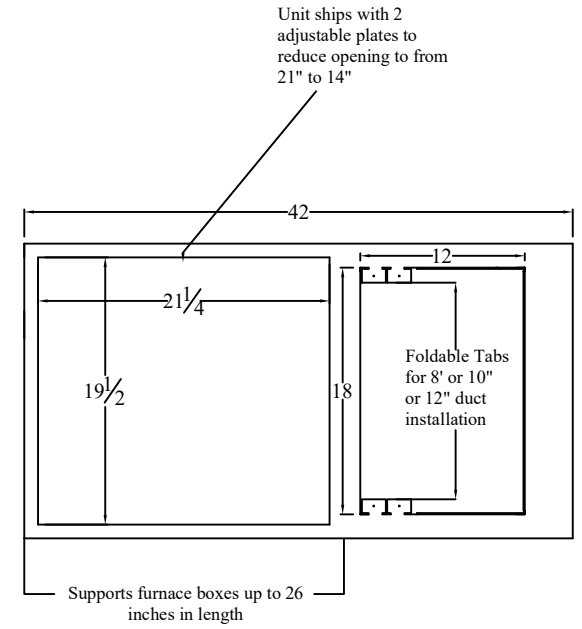
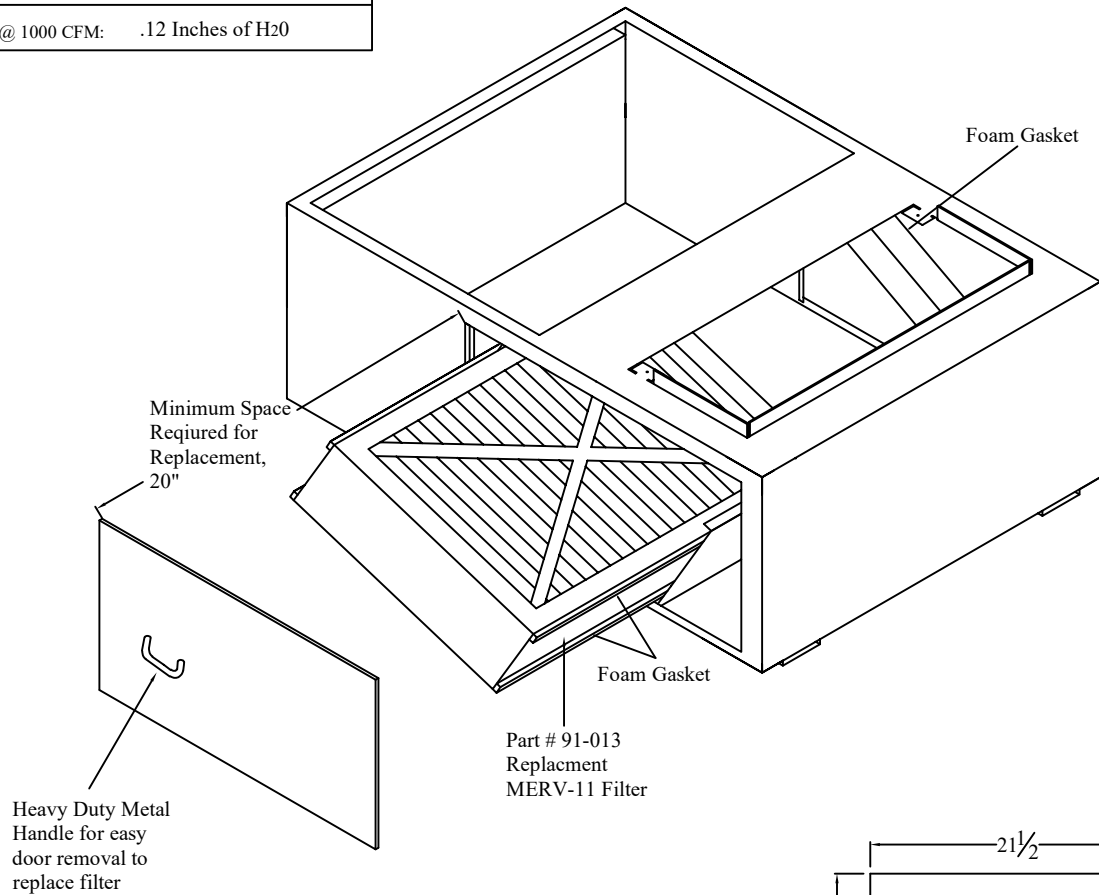

Ultravation, Inc. 67 Tubbs Ave Brandon Vermont 05733. Ph: 802-247-0034 Fx: 802-247-0033 www.Ultravation.com	Part #: 90-043	Drawing #:	Rev -*
	Description: Un-insulated Air Handler support box AHSB system, w/ 20x20x5 MERV-11 filter, un-painted, galvanized finish.		
Date: 11/09/12	Scale:	Creator: WEF	