

4

3

2

1

Specifications

Replacement Lamp	AS-IH-1001
Lamp Life	Up to 18,000 hrs
Power Consumption	16 Watts
Carbon Content	709 in ² /4.92 ft ²

PCO Panels are shipped closed position. Open using these actuator levers after installation (Never move panels other than with actuators).

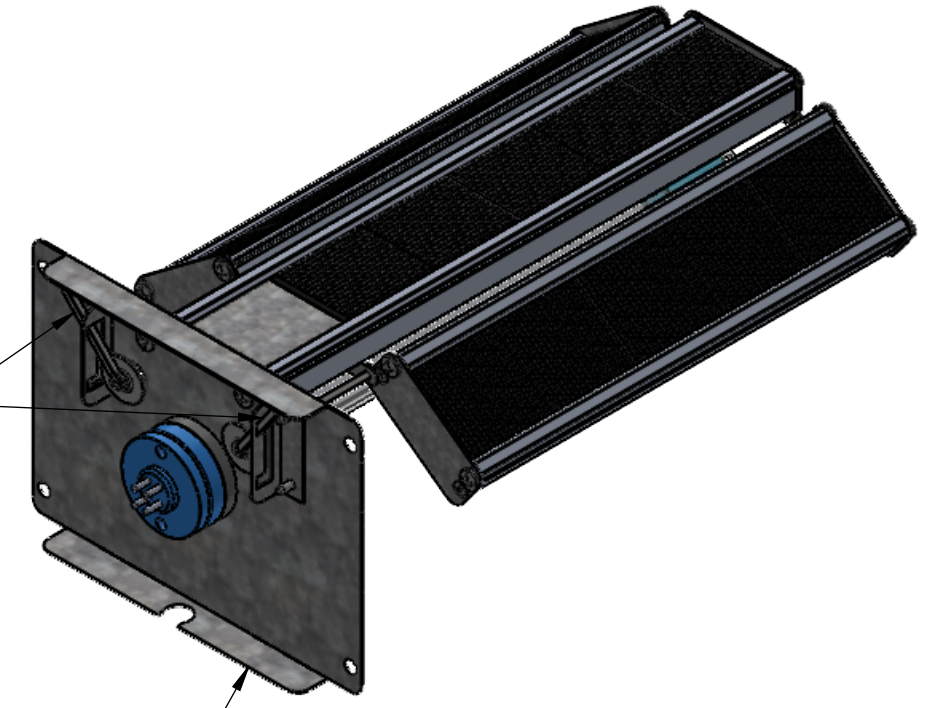

EZ Mounting Plate. Modular design for small footprint & super easy installation/lamp changes

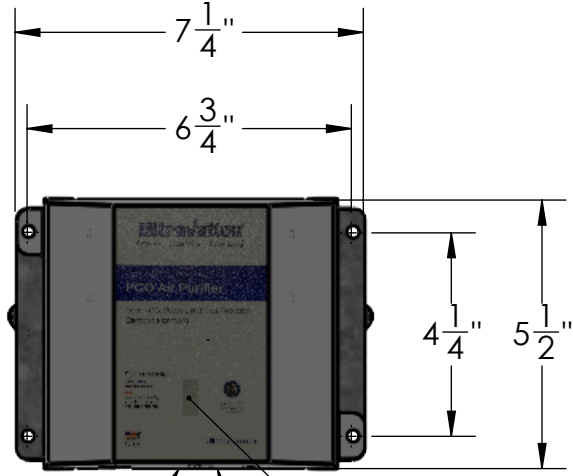
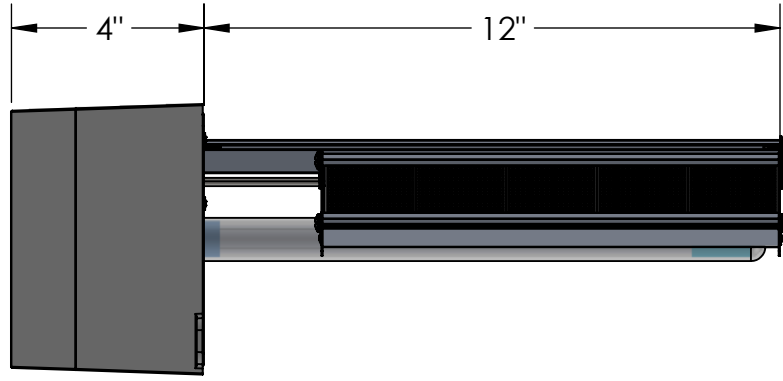
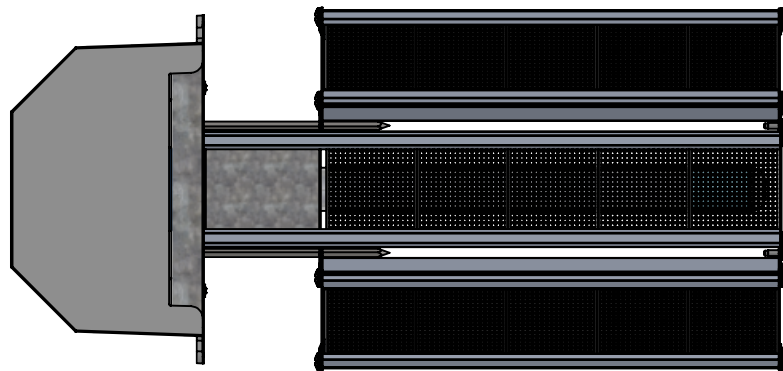

Ø 4 1/4" Recommended Hole size for Installation

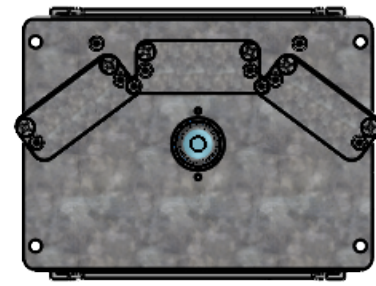

Shown open for for normal operation

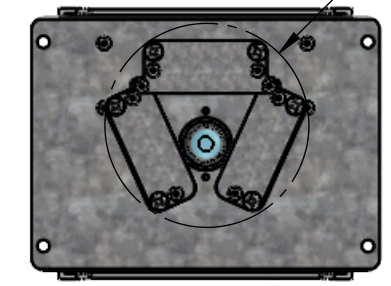

Shown close for installation

24VAC Input

System Monitor
Blue LED: Normal System Operation
Red LED: Lamp/Service Required

Reset Button
Press and Hold for 10 seconds after every Service

PROPRIETARY AND CONFIDENTIAL
THE INFORMATION CONTAINED IN THIS DRAWING IS THE SOLE PROPERTY OF <INSERT COMPANY NAME HERE>. ANY REPRODUCTION IN PART OR AS A WHOLE WITHOUT THE WRITTEN PERMISSION OF <INSERT COMPANY NAME HERE> IS PROHIBITED.

		UNLESS OTHERWISE SPECIFIED:		NAME	DATE
ULTRAVATION, INC. 67 TUBBS AVENUE BRANDON VT. 05773 PHONE (866) 468-8247		DIMENSIONS ARE IN INCHES TOLERANCES: FRACTIONAL ± ANGULAR: MACH ± BEND ± TWO PLACE DECIMAL ± THREE PLACE DECIMAL ±		DRAWN	H Kelley 4/3/2026
APPLICATION		INTERPRET GEOMETRIC TOLERANCING PER: MATERIAL FINISH		CHECKED	
DO NOT SCALE DRAWING		COMMENTS: Whole House PCO Air Purifier		ENG APPR.	
				MFG APPR.	
				Q.A.	
				TITLE: SS-UVCAT-1224	
		SIZE	DWG. NO.	REV	
		B	SS-UVCat-1224-DDS		
		SCALE: 1:4	WEIGHT:	SHEET 1 OF 1	

4

3

2

1

B

B

A

A