

Specifications	
Replacement Lamp: AS-IH-1024	
Power Consumption: 0.15A @ 120V	

SYSTEM MONITOR  
 GREEN/BLUE LED: SYSTEM OPERATION GOOD  
 RED LED: LAMP/SERVICE REQUIRED

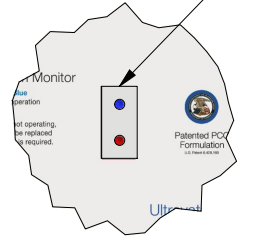

DETAIL C  
 SCALE 1 / 2

The PCO Panels ship in the closed position.  
 Only open for operation after mechanical installation.  
 Never move the panels by hand only use the actuators

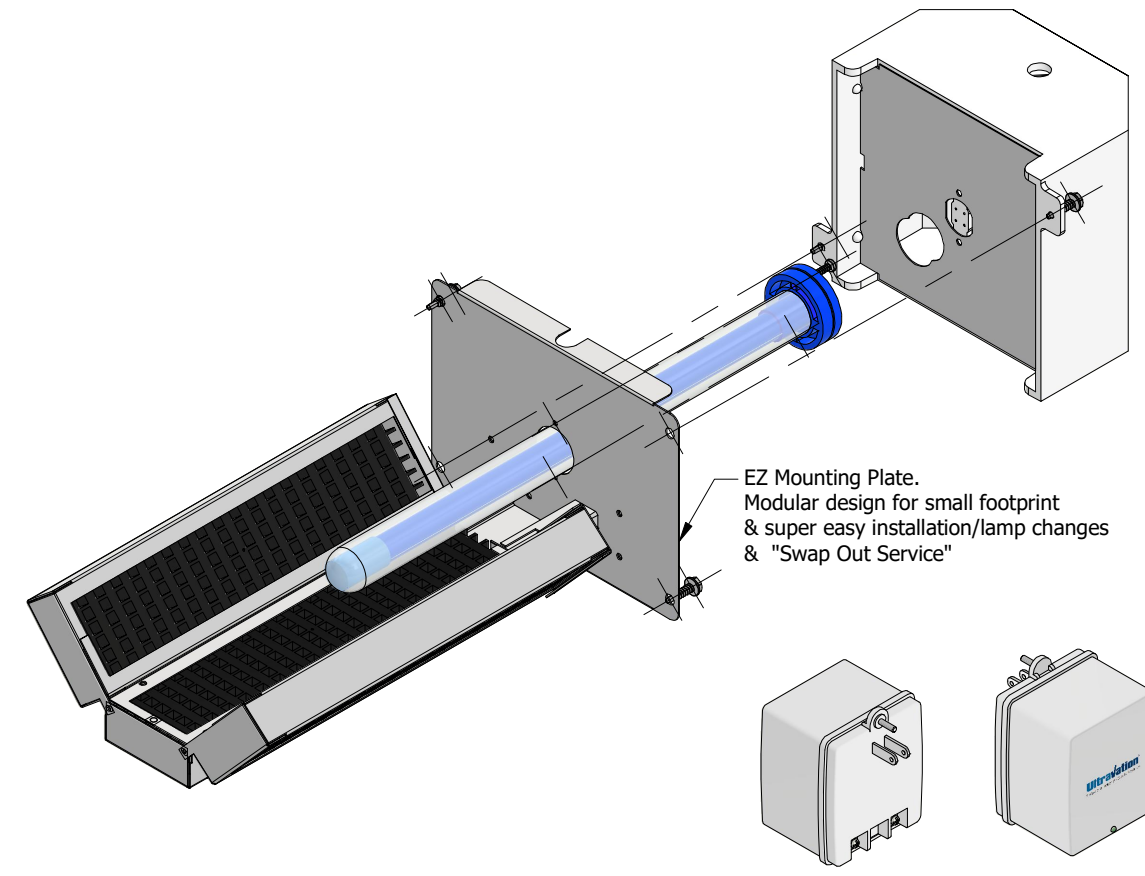
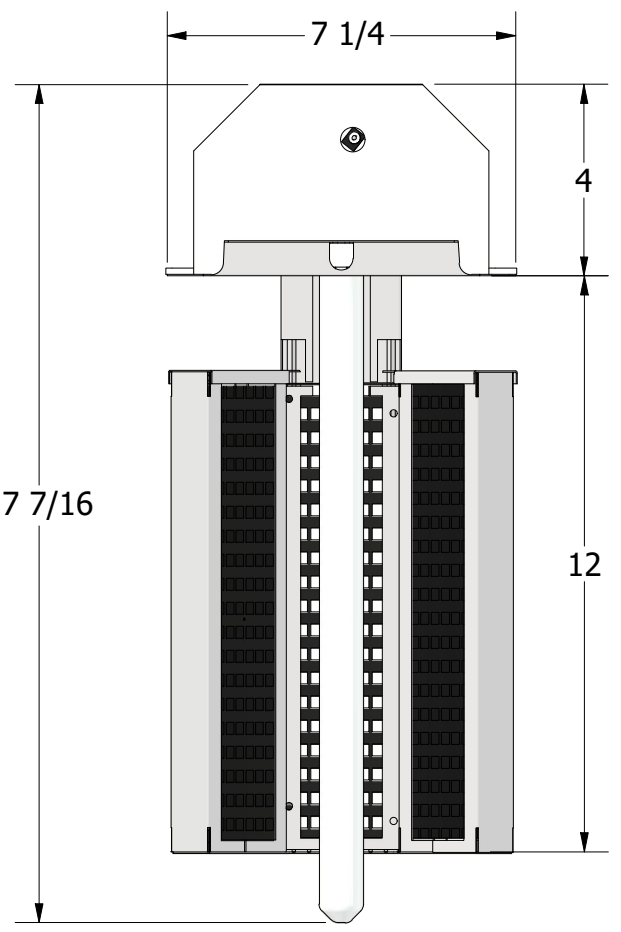
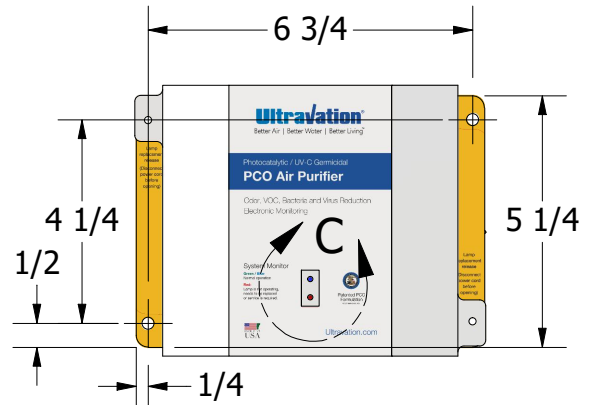
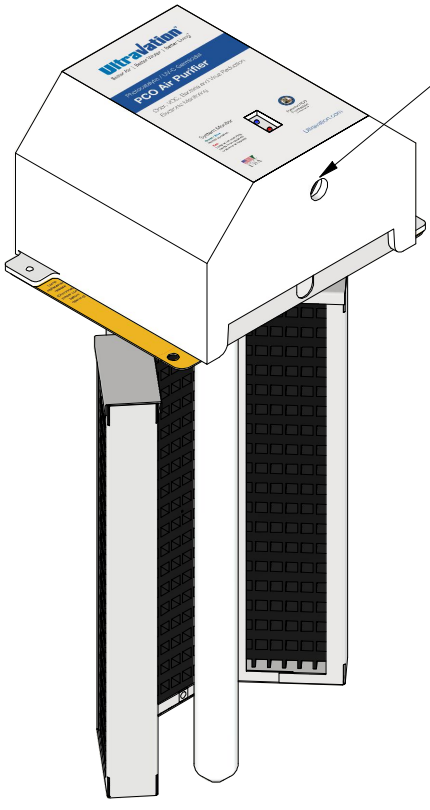
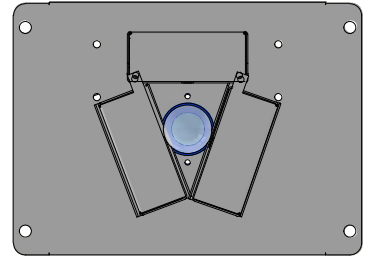
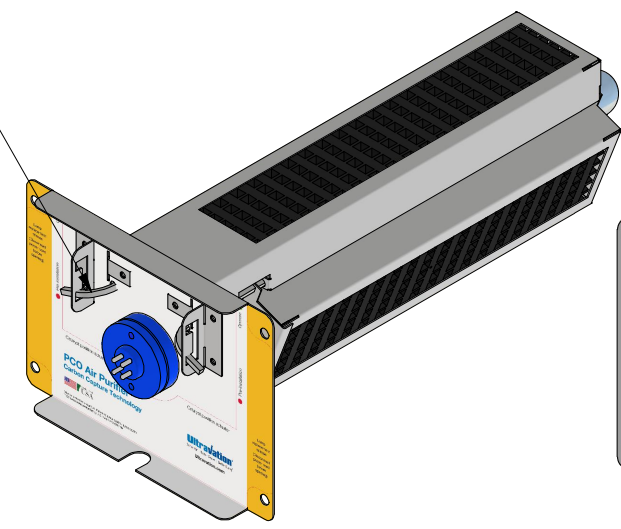
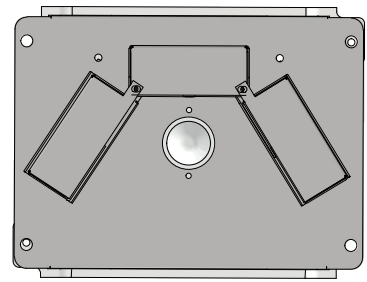

(1) 94-135 120V Wall Plug-In Power Supply Provided With Unit.  
 [The unit itself is 24V input, use the transformer for 120V use]

DRAWN Anik D. CHECKED	3/2/2023	Ultravation Inc. 67 TUBBS AVE, BRANDON VT-05733. 866-468-8247. www.ultravation.com		
QA		TITLE <b>UVCat-1200</b>		
MFG		Whole house PCO air purifier. Equipped with activated carbon treated with Silver Ag and Zinc ion coating. 120 V Wall Plug In Option Provided.		
APPROVED		SIZE <b>A3</b>	DWG NO <b>UVCat-1200</b>	REV N/A
All Dimensions are in INCHES		SCALE 1 / 4	Tolerance ±0.031	SHEET 1 OF 1