

Specifications

Coverage: 500 sq ft to 5000 sq ft spaces,adjusts up to 7.5 ton / 3000CFM

Replacement Lamp: AS-IH-1013-1

Power Consumption: 0.67 A @ 24V

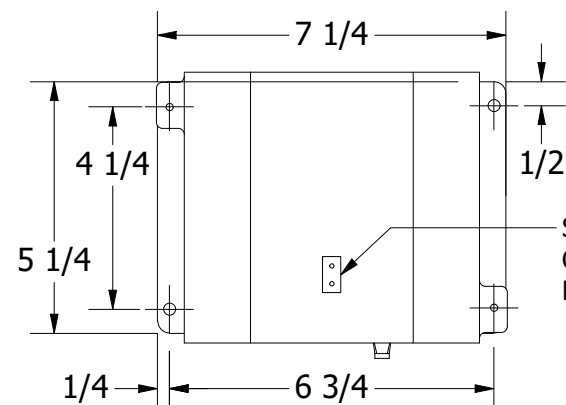

SYSTEM MONITOR
GREEN/BLUE LED: SYSTEM OPERATION GOOD
RED LED: LAMP/SERVICE REQUIRED

Input: Power In 24V,50/60Hz, 2.5 Amp

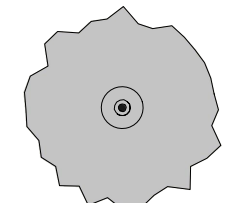
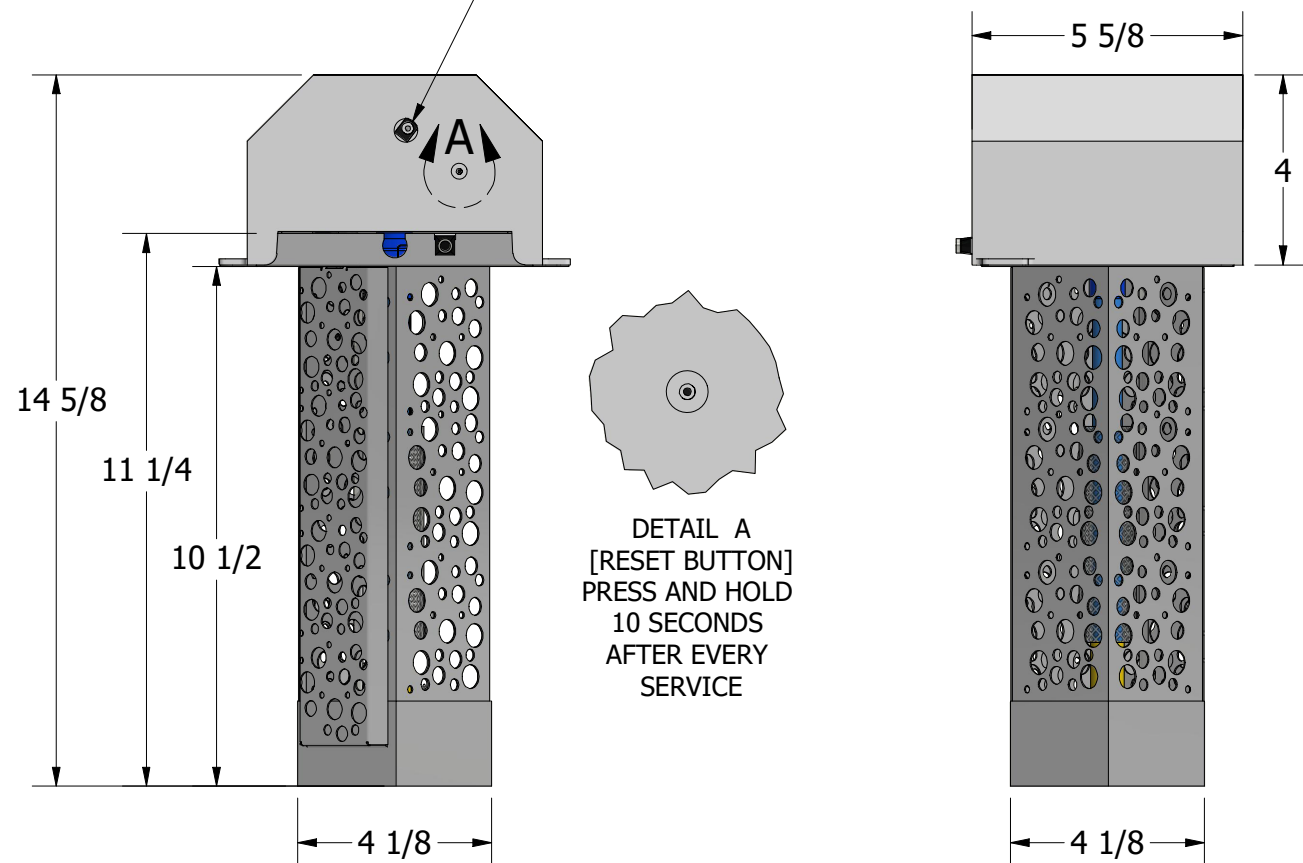

DETAIL A
[RESET BUTTON]
PRESS AND HOLD
10 SECONDS
AFTER EVERY
SERVICE

Ships with 40VAC multi-tap transformer
Input Voltage - Transformer 120V AC; 208V AC; 240V AC; 277V AC

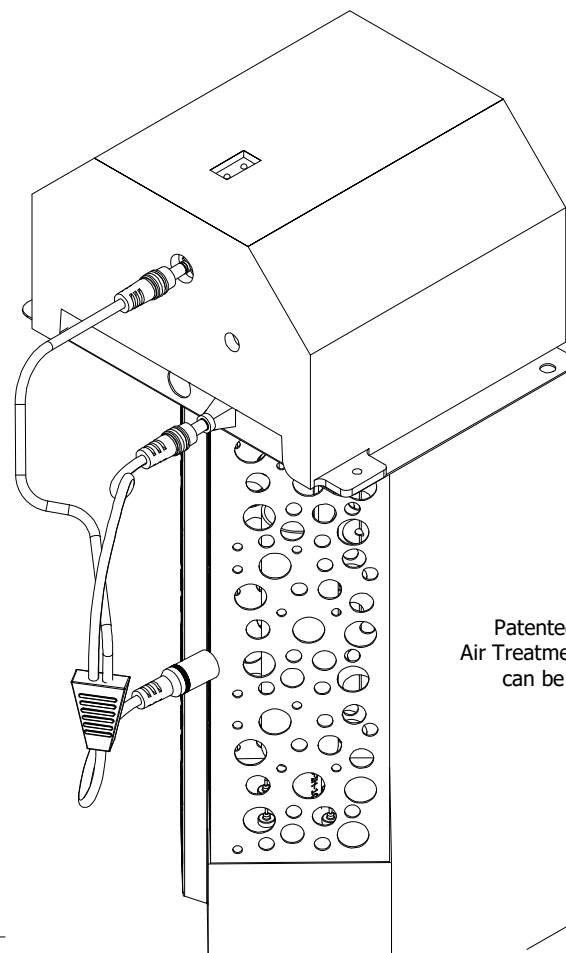

Patented adjustable dual spectrum
Air Treatment System- Photon clarifier
can be calibrated in sq. ft. or CFM

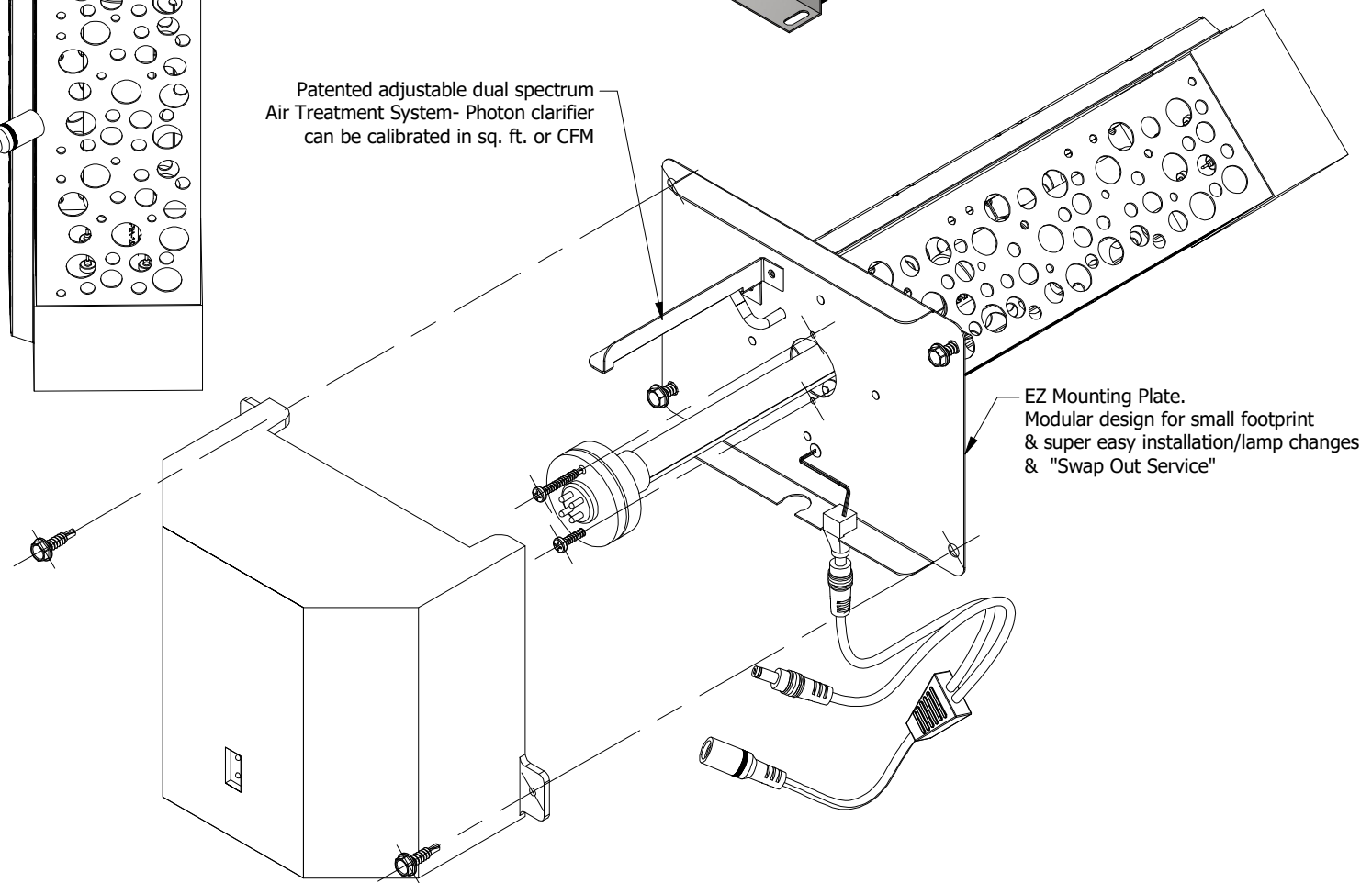
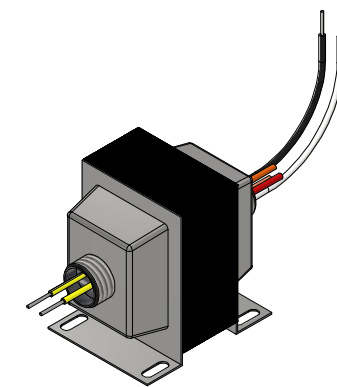

EZ Mounting Plate.
Modular design for small footprint
& super easy installation/lamp changes
& "Swap Out Service"

DRAWN Anik D.	1/1/2022	ULTRAVATION INC. 67 TUBBS AVE, BRANDON VT-05733. 866-468-8247. www.ultravation.com		
CHECKED B. FOWLER	2/28/2023			
QA		TITLE		
MFG		PTXGI-1224		
APPROVED		PCO Air Purifier 24VAC with 4NP Ion Generator with duct board plate.		
		SIZE A3	DWG NO PTXGI-1224	REV N/A
All Dimensions are in INCHES		SCALE 1/3	Tolerance ±0.031	SHEET 1 OF 3